

PALLMANN

Economical Recycling of Carpet and Floor Covering

Granulation of Carpet and Floor Covering Waste with the Knife Mill, type PS-H



For the economical granulation of carpet and floor covering in form of edge trims, tiles, sheets or skeletons

The end product size can be easily defined by choosing a suitable screen.

Material for reusing in the extrusion or for scattering can be processed.

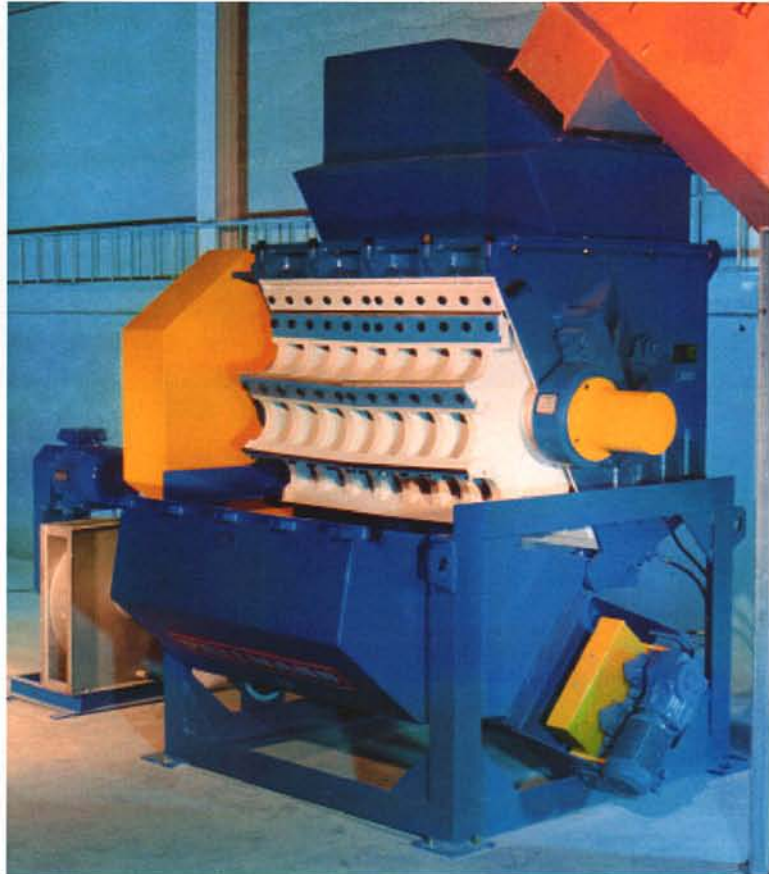

Decisive advantages

- *Compact construction with very low infeed height*
- *Very robust and durable construction*
- *Easy screen and knife changing due to maintenance-friendly design*
- *Installation possible without an additional foundation*
- *Very economical; high throughput rate*
- *Granulation with a low percentage of fines*

Economical Recycling of Carpet and Floor Covering

Method of operation

The waste material is fed into the granulator by conveyor belt. Granulation takes place between the knives of the heavy-duty slant-cut rotor and the housing knives. The size of the end product depends on the hole size of the built-in screen, which is determined by the customer.

The end product is discharged into a suction bin and can be sacked underneath the cyclone or transported directly into a storage bin for further processing.

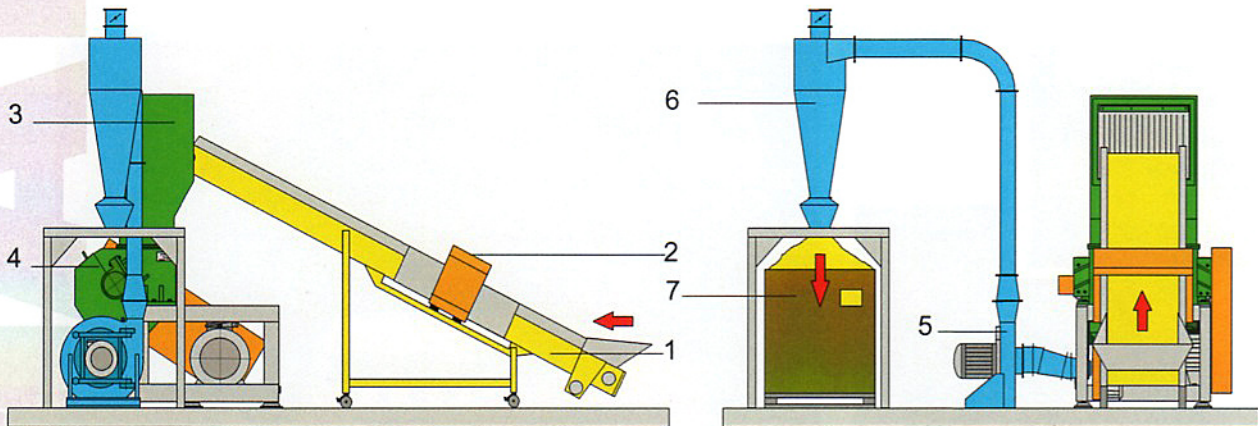

- | | |
|------------------------|----------------------------|
| 1. Conveyor belt | 5. Blower |
| 2. All-metal separator | 6. Cyclone |
| 3. Material feed chute | 7. Material collecting bin |
| 4. Knife mill | |

Technical Data

Type PS-H	Infeed opening mm	Rotor Ø mm	Motor kW	Throughput rate* kg/h	Weight kg	Dimensions		
						Length mm	Width mm	Height mm
400 x 500	408 x 510	400	22 - 45	250 - 800	1400	1315	1065	995
400 x 700	408 x 710	400	30 - 55	300 - 1100	1500	1245	1285	1050
400 x 900	408 x 920	400	37 - 55	350 - 1200	1600	1245	1500	1050
500 x 700	510 x 715	500	37 - 55	350 - 1300	2100	1560	1415	1200
500 x 900	510 x 920	500	45 - 75	400 - 1600	2300	1560	1610	1220
600 x 900	665 x 920	600	45 - 75	500 - 1800	3200	1970	1630	1365
600 x 1100	610 x 1120	600	55 - 90	600 - 2200	3600	2000	1830	1400
800 x 1100	905 x 1120	800	75 - 132	800 - 2900	4300	2300	1920	1800
1000 x 1400	1120 x 1420	1000	110 - 160	1100 - 4000	10400	2720	2525	2135
1000 x 1600	1120 x 1625	1000	132 - 250	1200 - 4500	11000	2520	2960	2300

*Throughput rate based on the granulation of carpet and floor covering using an 8 mm screen. Additional machine sizes are available.



PALLMANN

Maschinenfabrik GmbH & Co.KG.
Wolfslochstrasse 51 Postfach 1652
66482 Zweibrücken Germany
Phone: +49-6332-802-0 Fax: +49-6332-802-521
E-mail: plast-chem@pallmann-online.de

<http://www.pallmann.de>