

PALLMANN

Knife Ring Flaker PZKR



Knife Ring Flaker PZKR

100% Utilization of Wood

Wood is scarce and expensive. Full utilization is therefore a must. We assist you with machines, especially built for the preparation of waste wood assortments. More than 5000 PALLMANN Knife Ring Flakers installed worldwide are synonym for high flake quality, reliability, precision and durability. Due to constant further development of machines and material, we are again and again resetting the standards in flaking technology.

Flake quality and constancy are the decisive development criteria.

PALLMANN flakers are flexible and can individually adapt to your flaking requirement. Professional chip preparation results in correct flakes for particleboards that meet any demand.



Method of Operation

By means of a feeding system, consisting of a vibratory feed trough and a magnetic drum, the chips are transported into the flaking chamber through the gravity separator "Cleanomat" and a distribution system.

The rotating turbo impeller accelerates the chips and pushes them against the interior of the knife ring where they are flaked by the knives installed therein. The desired flake thickness is for the most part determined by the knife projection. The flakes are transported through a defined gap between knife and wear shoe and are discharged vertically to below out of the machine.

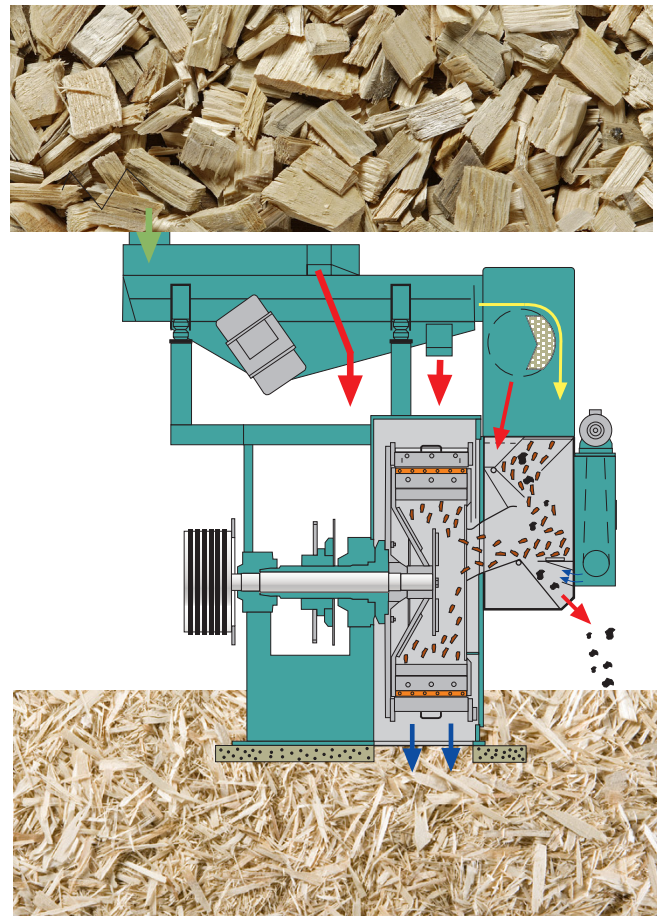

The well-proven counter-rotating principle

The knife ring is chain-driven by a gear motor counter-rotating to the impeller. This proven counter-rotating operating principle of PALLMANN flakers assures uniform use of all knives and reliable discharge of the flakes. The result is a high cutting performance, constant flake quality and uniform wear.

Furthermore, the counter-rotating principle of the knife ring ensures proper flake discharge even at extremely high moisture contents, i.e. no clogging of the flake channels and no material accumulation on the outside of the knife ring.



Constant flake quality - specifically set

Knife Setting

The knife packages, consisting of knife holding plates and knives are, as a standard, set outside the machine in a setting device to the precisely desired knife projection.

When using a sharpening- and setting robot, type PZSE, the setting of the knives is performed fully automatically.

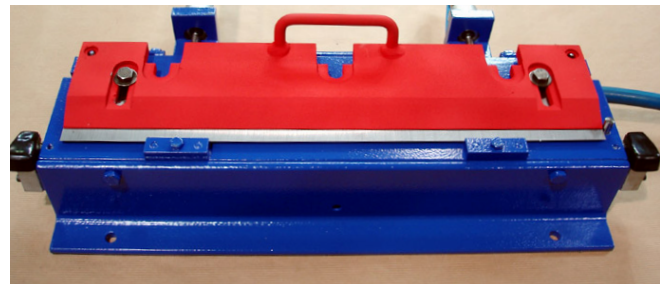

Setting of the beater plates

The simple and precise setting of the impeller beater plates in the machines by means of a fixture permanently ensures good flake quality.



Fighting wear

Easily exchangeable, respectively re-grindable wear parts protect the interior of the knife ring and the turbo impeller. Good flake quality can also be achieved in such a way over longer periods of time.

- | | |
|-----------------|-----------------------|
| 1. Wear plate | 5. Wear segment |
| 2. Beater plate | 6. Impeller |
| 3. Wear shoe | 7. Knife carrier ring |
| 4. Knives | 8. Knife carrier |

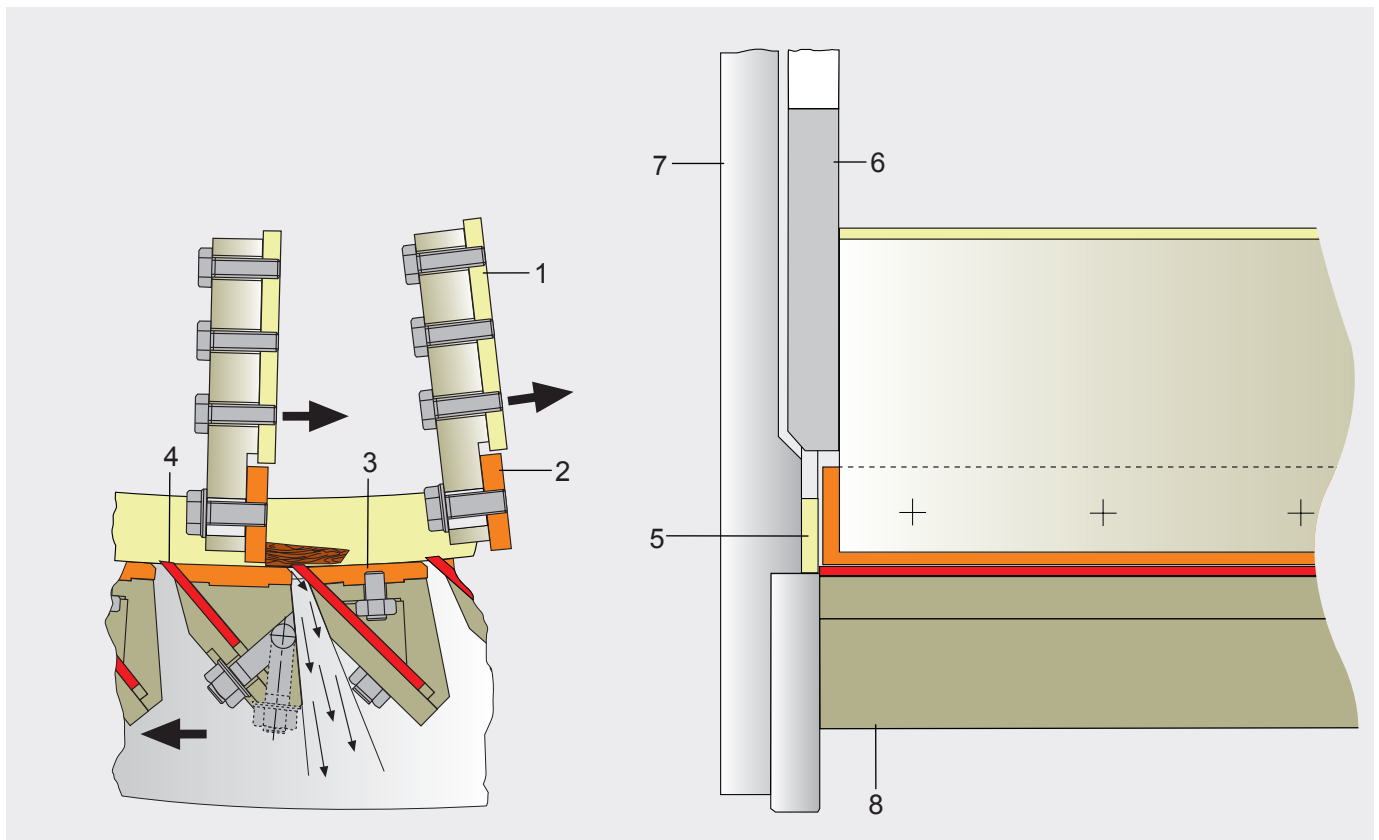

Proven accessories

Gravity separator CLEANOMAT

- Removal of foreign objects in accordance with specific material density
- Adjustable material- and air guiding flaps for optimum adjustment to various feed materials and operating conditions
- Cross current fan for the production of an even air stream over the entire material feeding width
- Increased operational lifetime of all wear parts



Cleaning of the knife ring

- Automatic cleaning of the rotating knife ring during the shutdown cycle
- Optimum prerequisite for downstream knife changing
- Use of air or water for cleaning

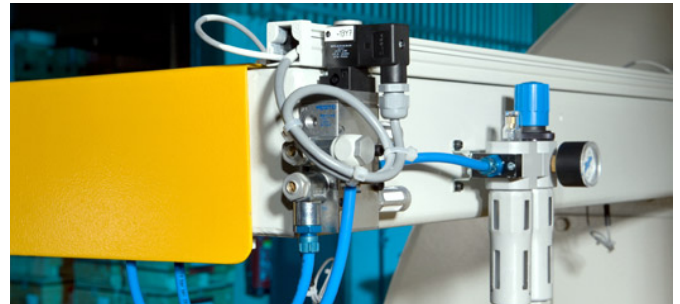

Knife ring coding

- Identification of all knife rings within one plant
- Allocation of electronic data in the sharpening- and setting robot

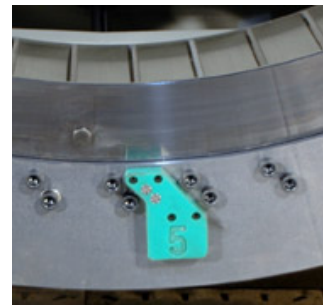

Sharpening- and Setting robot PZSE

- Fully automatic sharpening and setting of the knives in the knife ring
- Grinding of the wear shoes for optimum knife projection
- Control of wear tolerances of knives and wear shoes
- Optimum wet grinding process
- Cleaning of grinding emulsion via band filter
- Achievement of optimum knife cutting circle and knife projection



Proven installation

Optimum capacity

Knife ring flakers should always be fed by means of a vibratory feeding trough in order to achieve continuous material feeding and optimum utilization of the installed electric force. Our integrated feeding system represents the ideal solution and consists of:

- Vibratory feeder with coarse- and fines discharge
- Transition cover with integrated magnetic drum separator for separation of ferrous contaminants
- Heavy gravity sifter "Cleanomat" for separation of stones and NE-metals etc.

The air produced by the knife ring flaker should be dissipated by means of an exhaust system with integrated dust filter.

Advantages

- Constant flake quality
- High throughput rate
- Quick knife change
- Precise knife setting
- Optimum wear protection
- No clogging at high moisture content
- Economical in operation/maintenance
- Robust, reliable and long lifetime

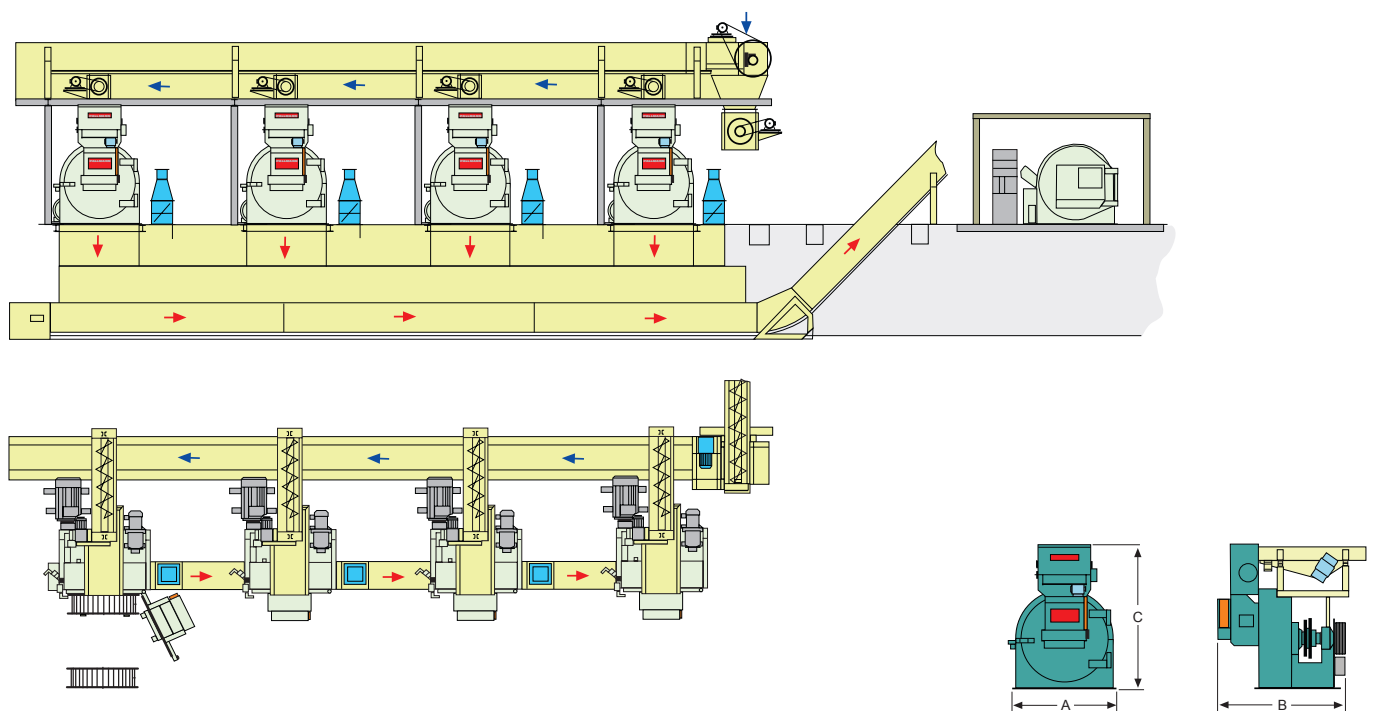

Type PZKR		8-300	12-450	14-450	14-450	15-500	16-600	20-600
Dimensions:	mm							
Width	A	1670	2150	2200	2200	2350	2600	3180
Depth	B	2300	2700	2700	2700	2800	3100	3250
Height	C	2400	2930	2930	2930	3120	3460	4150

Technical Data

Type PZKR		8-300	12-450	14-450	14-450	15-500	16-600	20-600
Drive, impeller	kW	100-132	200-250	250-315	250-315	315-350	350-400	450-630
Drive, knife ring	kW	11-18,5	18,5-22	22-30	22-30	30-37	37-45	45-55
Cutting circle	mm	800	1200	1400	1400	1500	1600	2000
Number of knives	St.	28	42	49	66	66	74	92
Knife lengths	mm	300	450	450	450	500	600	600
Number of impeller plates	St.	12	18	21	21	22	24	30
Knife changing time	min	5-10	15	15-20	15-20	15-20	20-25	20-25
Weight	kg	2950	6500	7500	7500	8500	10800	20000
Air capacity	m ³ /h	4200	7200	8400	10200	11600	15400	18000

Throughput rate in to b.d./hr	Medium flake thickness (mm)	8-300	12-450	14-450	14-450	15-500	16-600	20-600
Conifers	0,5	2.7	6.0	7.1	9.5	10.6	14.2	17.7
	0.6	3.2	7.2	8.4	11.3	12.5	17.0	21.2
	0.7	3.7	8.4	9.8	13.2	14.7	20.0	24.8
	0.8	4.3	9.6	11.2	15.1	16.8	22.7	28.3
High density wood	0.5	2.9	6.6	7.7	10.4	11.4	15.3	19.0
	0.6	3.5	7.9	9.2	12.4	13.6	18.4	22.8
	0.7	4.1	9.3	10.8	14.6	16.1	21.4	26.6
	0.8	4.7	10.5	12.3	16.6	18.4	24.5	30.4
Low density wood	0.5	1.9	4.2	4.9	6.6	7.3	9.8	12.1
	0.6	2.3	5.1	5.9	8.0	8.8	11.8	14.5
	0.7	2.6	5.9	6.9	9.3	10.3	13.7	16.9
	0.8	3.0	6.8	7.9	10.6	11.8	15.7	19.3

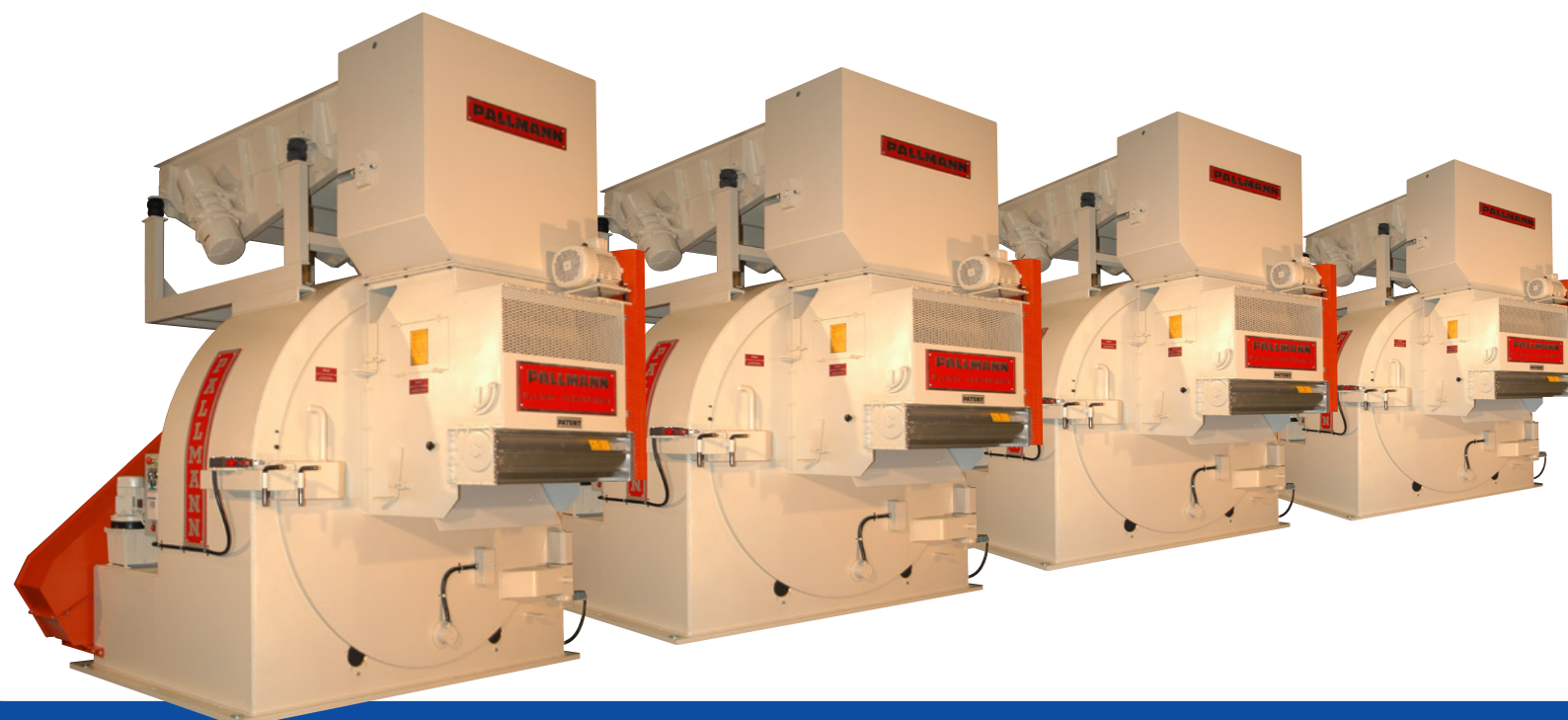



The Pallmann Group

The Pallmann Group is the leading manufacturer of size reduction machinery for the wood products industry. Pallmann Maschinenfabrik designs, manufactures and supplies tailor-made, individual or complete solutions for the processing of raw material for MDF, OSB and particleboard plants. At its headquarters in Zweibrücken, Pallmann company operates the world's largest research and development center for size reduction technology as well as a training and service center. More than 130 test machines are available for the preparation of various raw materials including subsequent laboratory analysis on individual scale. In addition to the manufacturing plants in North- and South America, the Pallmann group has a worldwide sales and service network.



The Pallmann Programm

Engineering and Service:

Design and Manufacturing
Research and development
Tests at industrial scale
Laboratory analysis
Worldwide service
Spare parts
Control systems
Process monitoring
Installation and start-up
Maintenance and repair
Project Management

System solutions for:

Flake production
Fiber production
OSB-production
Recycling
Annual plants preparation
Thermal usage

Single machines:

Debarkers
Universal flakers
Long log flakers
Disc chippers
Drum chippers
Knife ring flakers
Double stream mills
Hammer mills
Drum shredders
Bale breakers
Depithers
Refiners
Sifting-/classifying systems
Chip washing systems
Re-chippers
Pre-crushers
Impact hammer mills
Screen ring mills
Wing beater mills

PALLMANN America Inc.
6420-A1, Rea Rd. Suite 335 Charlotte
NC 28277
USA
Phone +1 704 543 4400
Fax +1 704 543 5580
E-mail: sales@pallmannamerica.com
<http://www.pallmannamerica.com>

PALLMANN do Brasil Ind. e Com. Ltda.
Av. Presidente Juscelino, 11 56
09950-370 Diadema S.P.
Brasil
Phone +55 11 4075 3044
Fax +55 11 4075 4968
E-mail: pallmann@pallmann.com.br
<http://www.pallmann.com.br>

PALLMANN Moskau Office
Leninskij prospekt dom 158
Office Nr. 206
119571 Moskau
Russland
Phone +7 495 232 15 21
Fax +7 495 232 15 22
E-mail: info@pallmann.ru

PALLMANN Maschinenfabrik GmbH & Co.KG
Wolfslochstraße 51
66482 Zweibrücken
Germany
Phone +49 6332 802 0
Fax +49 6332 802 511
E-mail: wood@pallmann-online.de
<http://www.pallmann.eu>

PALLMANN Beijing Representative Office
Unit 13, 6th Floor of Tower A
Beijing Cofco Plaza
No.8, Jianguomennei Dajie, Dongcheng District
Beijing, China
Phone +86 10851 16826
Fax +86 10851 16825
E-mail: info@pallmann.com.cn